

Code No: 151AD

JAWAHARLAL NEHRU TECHNOLOGICAL UNIVERSITY HYDERABAD

B.Tech I Year I Semester Examinations, May/June - 2019

ENGINEERING GRAPHICS

(Common to CE, ME, EIE, MCT, AE, MIE, PTM)

Time: 3 hours

Max. Marks: 75

Answer all five questions

All questions carry equal marks

- - -

- 1.a) Draw a hyperbola when the distance between its focus and directrix is 50mm and eccentricity is $3/2$.
- b) The length of a scale with a RF of 2:3 is 20 cm. Construct this scale and mark a distance of 16.5 cm on it. [7+8]
- OR**
- 2.a) Construct a diagonal scale of 1 : 32 to read meters, decimeters, and centimeters, and long enough to measure 4 m. Show on this scale a distance of 2.46 m.
- b) A wheel of 50 mm diameter rolls without slipping on a straight road surface. Trace the path of the point of contact for one complete revolution of the wheel. [7+8]
3. A line PQ has its end P, 10 mm above the HP and 20 mm in front of the VP. The end Q is 85 mm in front of the VP. The front view of the line measures 75 mm. The distance between the end projectors is 50 mm. Draw the projections of the line and find its true length. [15]
- OR**
4. A regular pentagon of 30 mm side, is resting on one of its edges on HP which is inclined at 45° to VP. Its surface is inclined at 30° to HP. Draw its projections. [15]
5. Draw the projection of a pentagonal pyramid, whose base edge is 30 mm and axis is 40 mm long. The pyramid is resting on a horizontal plane with one of its base edges inclined at an angle of 30° with VP. [15]
- OR**
6. A cube of 40 mm edges is resting on one of its faces on the HP with a vertical face inclined to 30° to VP. It is cut by a section plane parallel to the VP and passing 15 mm away from the axis., Draw its top view and sectional front view. [15]
7. A triangular prism of base side 80 mm and axis 100 mm is resting on its base in the HP with a side of the base parallel to the VP. It is penetrated by another triangular prism of base side 40 mm and axis 100 mm having a face parallel to the HP. The axes of prisms bisect each other at right angles. Draw the projections of the combination, and show the lines of intersection. [15]
- OR**
8. A pentagonal prism of 30 mm base edges and 60 mm long, is resting on its base with an edge of base inclined at 40° to the VP. The prism is cut by a section plane whose V.T. is inclined at 30° to the HP and passes through a point 25 mm from the base along its axis. Develop the lateral surface of the truncated prism. [15]

9. Draw the isometric view of the object whose orthographic projections are given in figure 1. All dimensions are in mm. [15]

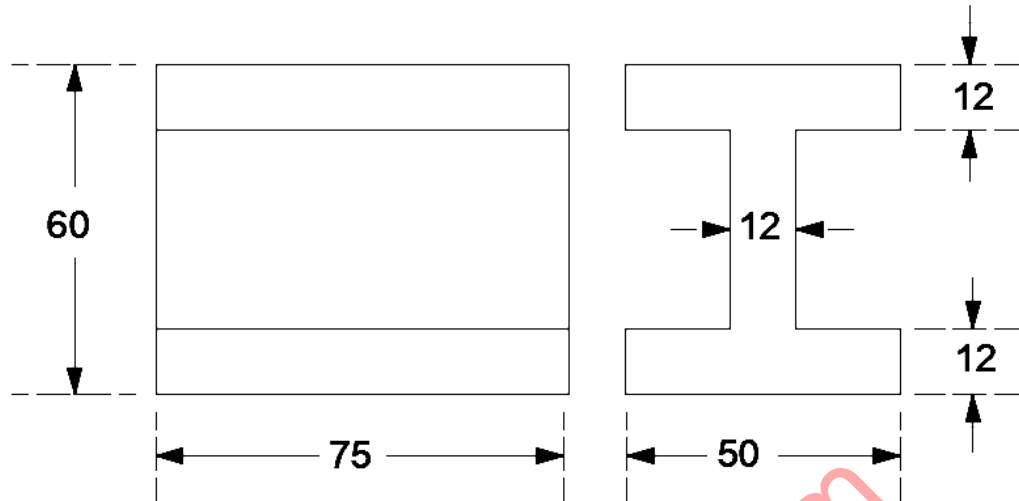

Figure: 1
OR

10. Draw the front view, top view, and side view of the object shown in figure 2. All dimensions are in mm. [15]

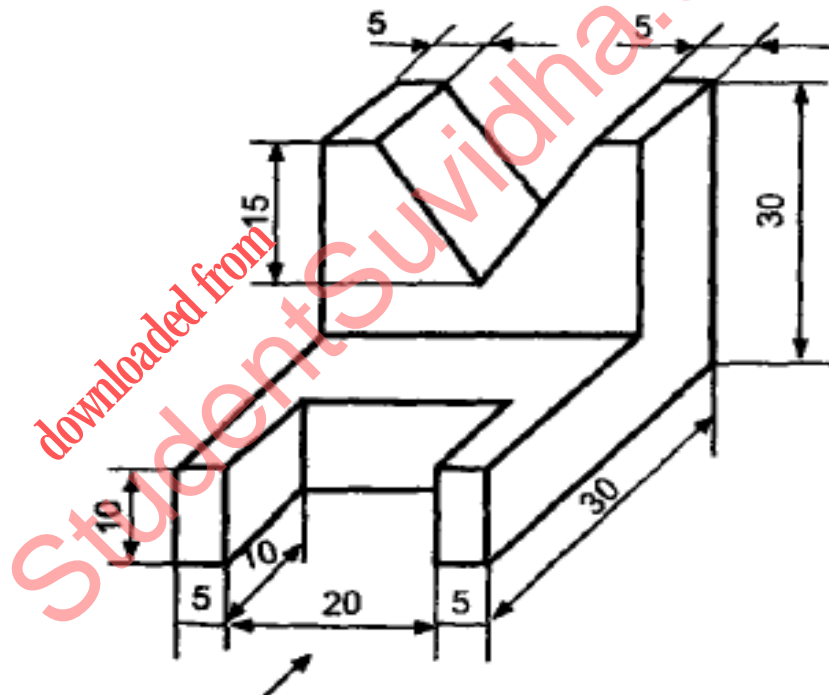

Figure: 2

---ooOoo---